

Product Dimensions

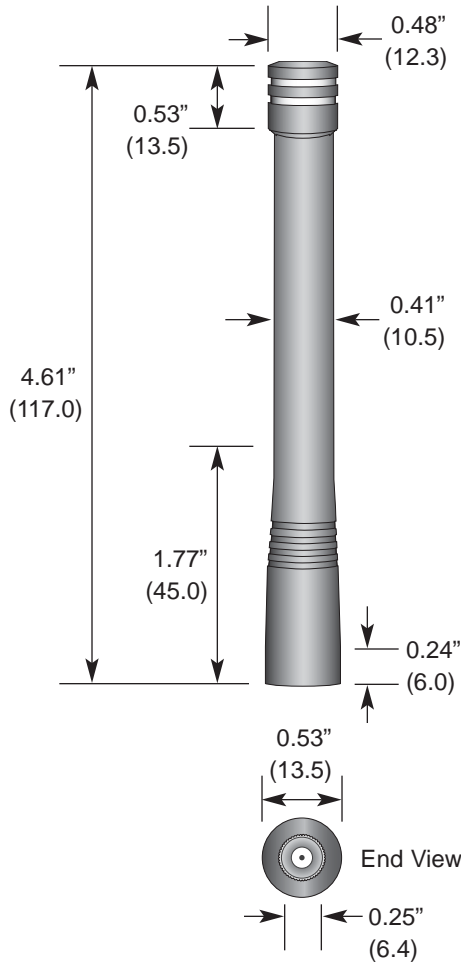

Description



This reduced-height 1/4-wave antenna is ready for years of use thanks to a flexible internal helical that is over-molded with a heavy-duty protective jacket. It's an excellent choice for outdoor applications or for use in adverse environments where the antenna must resist shock, harsh weather, and tampering. HD Series antennas attach via an FCC Part 15 compliant RP-SMA connector.

Features

- Reduced-height helical whip
 - Excellent performance
 - Omni-directional pattern
 - Very low VSWR
 - Heavy-duty construction
 - Damage-resistant
 - Fully weatherized
 - Flexible main shaft
 - Part 15 compliant RP-SMA connector
 - Use with plastic* or metal enclosures
- * Requires proximity ground plane

Electrical Specifications

- Center Freq. 315MHz
- Bandwidth 10MHz
- Wavelength 1/4-wave
- VSWR <2.0 typ. at center
- Impedance 50 ohms
- Connector RP-SMA

Electrical specifications and plots measured on 4.00" x 4.00" reference ground plane

Ordering Information

- ANT-315-CW-HD

VSWR Graph

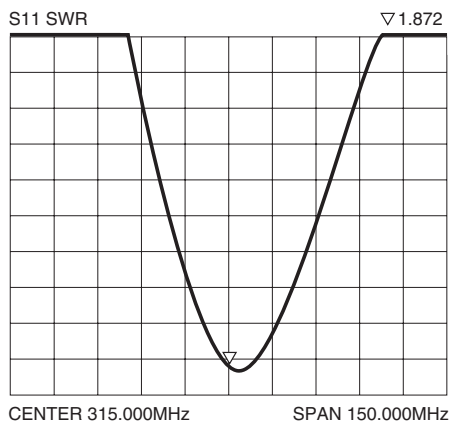

Typical VSWR

Polar Plot & Gain Information

Monopole antenna gain and radiation patterns are dependant on the ground plane and layout of the end product. Since antenna manufacturers do not measure on standardized ground references, comparison of published specifications is an unreliable indication of actual antenna performance in an end product. Optimum full-wave ground planes are impractical for the majority of products on which these antennas are used (the ground plane for 916MHz would be 26.5" in diameter, 418MHz would be 56.5" in diameter). For this reason, Antenna Factor tests and tunes antennas on reduced-size, compromised ground planes. To avoid mis-comparison or inappropriate application, gain and polar plots do not appear on this data sheet, but are available upon request for most products.